

**Figure A26 - Exploded view of the Test Station VA WPT3/Z1**

Table A11 shows the mechanical dimensions of the VA WPT3/Z1 and nominal vehicle shield.

**Table A11 - Mechanical dimensions of the Test Station VA WPT3/Z1**

	<b>Coil + Ferrite Only</b>	<b>Housing</b>	<b>Vehicle Shield Size</b>
L x W x H [mm]	284 x 284 x 12.6	300 x 300 x 20	800 x 800 x 1

## A.7.2 Electrical Specification

Figure A27 shows the electrical specification of the VA WPT3/Z1.

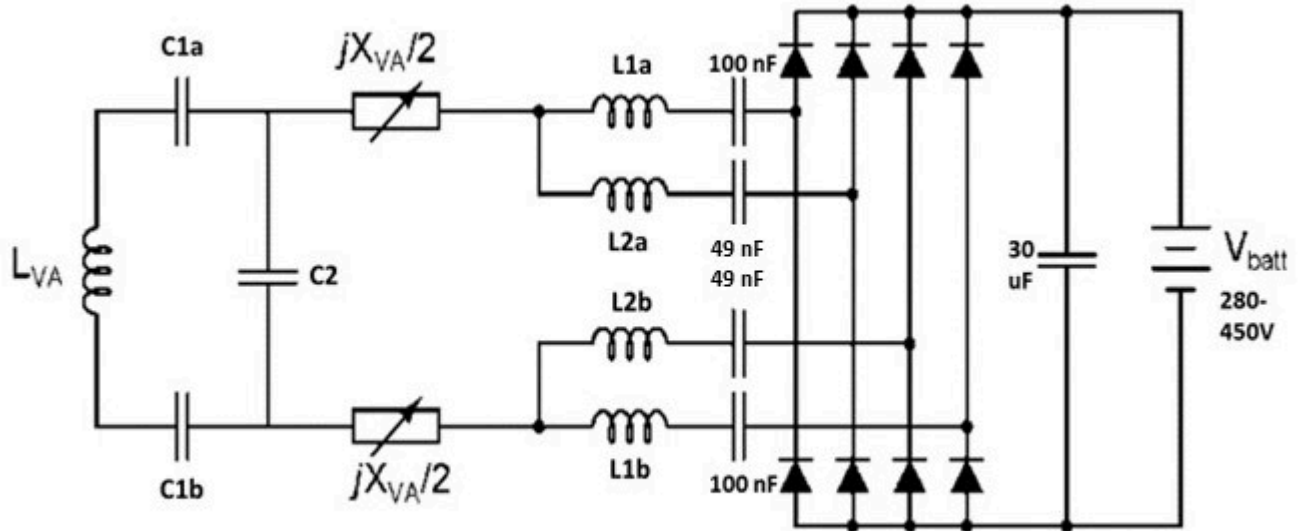

C1a, C1b [nF]	223
C2 [nF]	143
$jX_{VA}/2$ [ohms]	-15 to 0
L1a, L1b [ $\mu$ H]	54
L2a, L2b [ $\mu$ H]	54

**Figure A27 - Electrical specification of the Test Station VA WPT3/Z1**

Minimum and maximum values of secondary coil inductance  $L_{VA}$  are given in Table A12.

**Table A12 - Secondary coil inductance  $L_{VA}$**

$L_{Min}$ [ $\mu$ H]	45.0
$L_{Max}$ [ $\mu$ H]	47.0

## A.8 TEST STATION VA WPT3/Z2

This appendix provides the mechanical and electrical design specifications of the VA for power class WPT3 and gap class Z2 (VA WPT3/Z2).

NOTE: Specifications are designed for optimal operation with the Test Station GA specified in Appendix B.

## A.8.1 MECHANICAL SPECIFICATION OF THE VA WPT3/Z2

Figures A28 and A29 show the mechanical dimensions of the ferrite and the coil of the VA WPT3/Z2.

Typical properties of the ferrite material used in the VA are shown in Table A13.

**Table A13 - Typical ferrite properties**

Material	MnZn
Initial Permeability (25 °C)	>1000
Flux Density, $B_s$ (100 °C) ( $H = 1200 \text{ A/m}$ , 10 kHz)	>400 mT
Core Loss, $P_v$ (100 kHz, 200 mT, 100 °C)	<350 kW/m <sup>3</sup>

The lateral dimensions of the aluminum shield shown in Figure A29 are 800 x 800 mm, and the thickness should be 0.7 mm or larger.

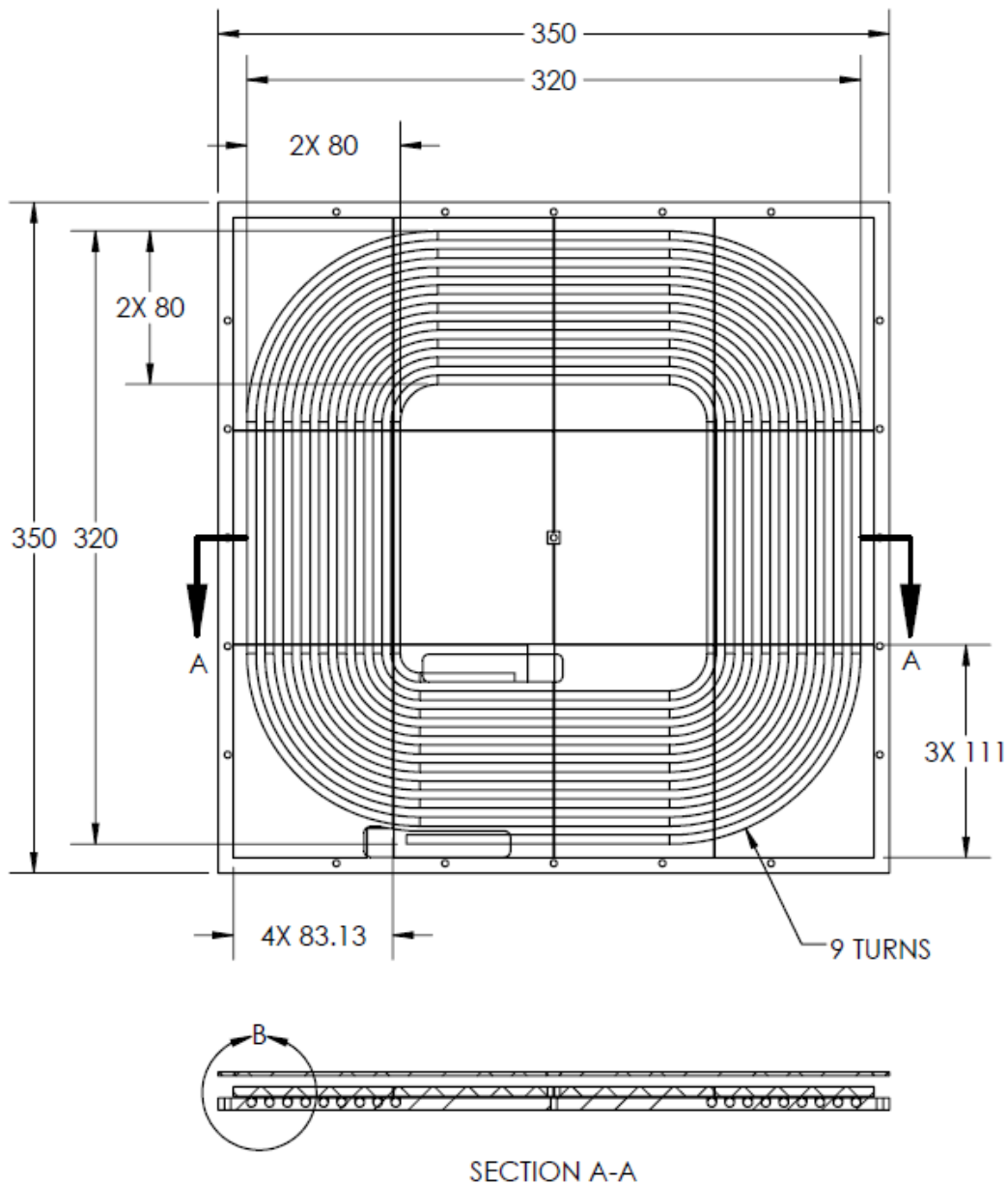
**Figure A28 - Mechanical dimensions of the Test Station VA WPT3/Z2**

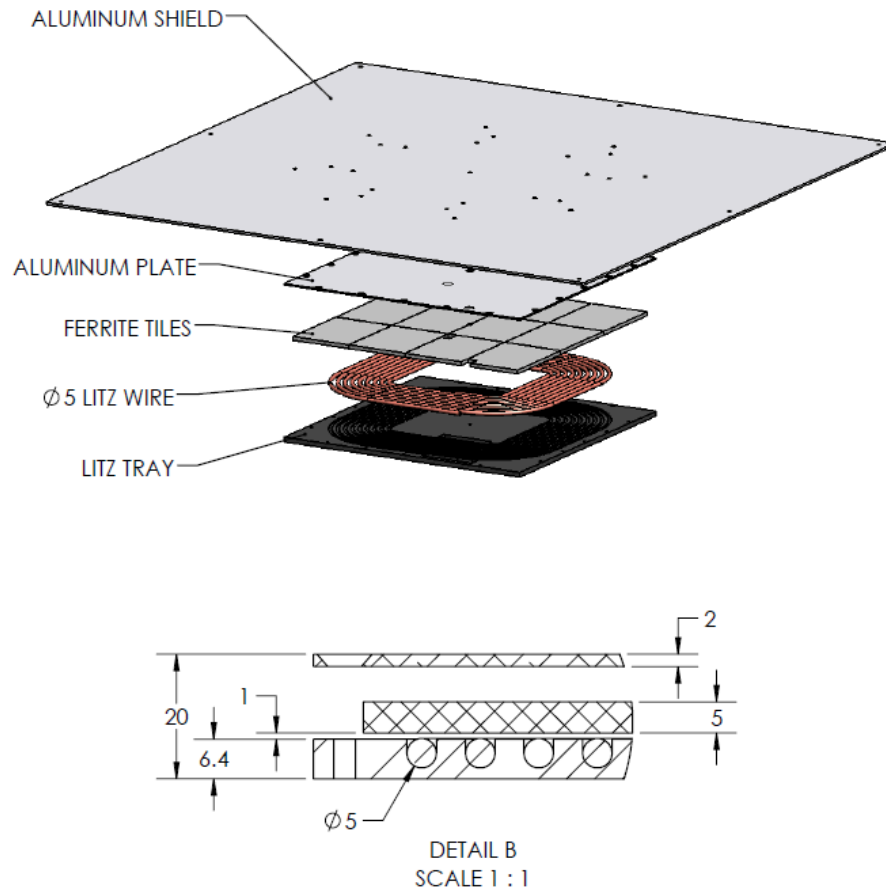

**Figure A29 - Exploded view of the Test Station VA WPT3/Z2**

Table A14 shows the mechanical dimensions of the VA WPT3/Z2 and nominal vehicle shield.

**Table A14 - Mechanical dimensions of the Test Station VA WPT3/Z2**

	<b>Coil + Ferrite Only</b>	<b>Housing</b>	<b>Vehicle Shield Size</b>
L x W x H [mm]	334 x 334 x 12.6	350 x 350 x 20	800 x 800 x 1

## A.8.2 Electrical Specification

Figure A30 shows the electrical specification of the VA WPT3/Z2.

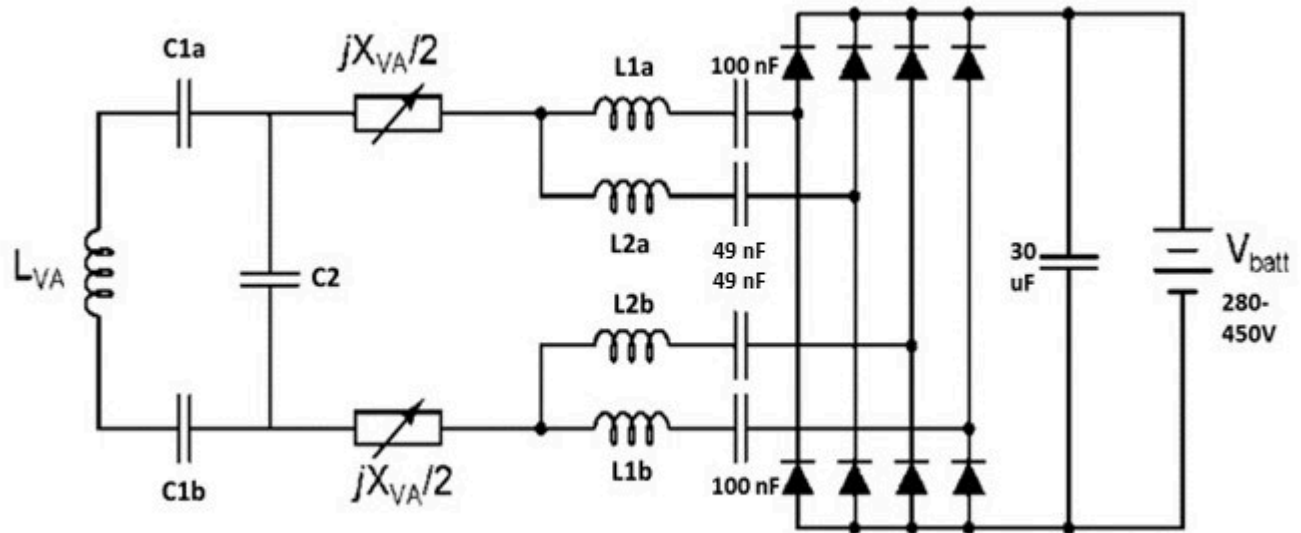

C1a, C1b [nF]	270
C2 [nF]	145
$jX_{VA}/2$ [ohms]	-15 to 0
L1a, L1b [uH]	54
L2a, L2b [uH]	54

**Figure A30 - Electrical specification of the Test Station VA WPT3/Z2**

Minimum and maximum values of secondary coil inductance  $L_{VA}$  are given in Table A15.

**Table A15 - Secondary coil inductance  $L_{VA}$**

$L_{Min}$ [ $\mu$ H]	43.1
$L_{Max}$ [ $\mu$ H]	44.0

## A.9 TEST STATION VA WPT3/Z3

This appendix provides the mechanical and electrical design specifications of the VA for power class WPT3 and gap class Z3 (VA WPT3/Z3).

NOTE: Specifications are designed for optimal operation with the Test Station GA specified in Appendix B.

## A.9.1 Mechanical Specification

Figures A31 and A32 show the mechanical dimensions of the ferrite and the coil of the VA WPT3/Z3.

Typical properties of the ferrite material used in the VA are shown in Table A16.

**Table A16 - Typical ferrite properties**

Material	MnZn
Initial Permeability (25 °C)	>1000
Flux Density, $B_s$ (100 °C) ( $H = 1200$ A/m, 10 kHz)	>400 mT
Core Loss, $P_v$ (100 kHz, 200 mT, 100 °C)	<350 kW/m <sup>3</sup>

The lateral dimensions of the aluminum shield shown in Figure A32 are 800 x 800 mm, and the thickness should be 0.7 mm or larger.

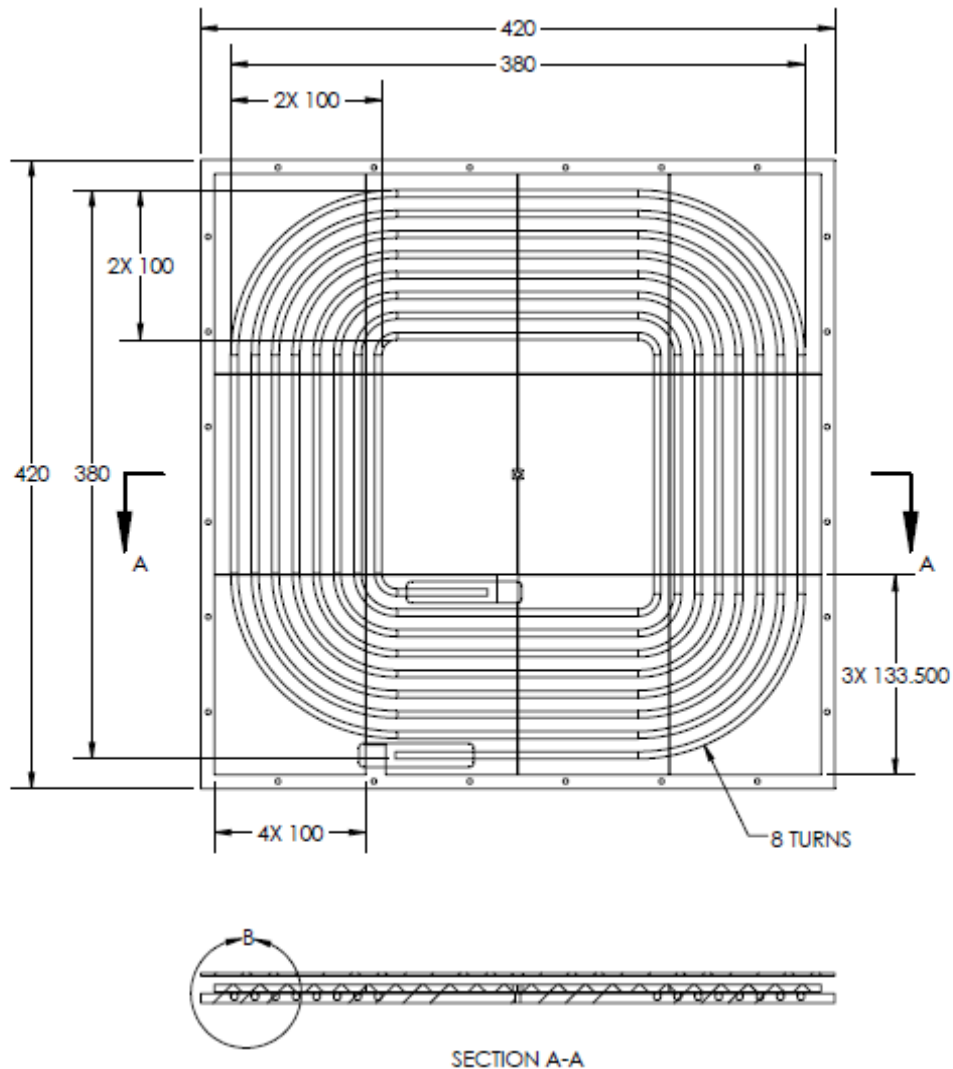
**Figure A31 - Mechanical dimensions of the Test Station VA WPT3/Z3**

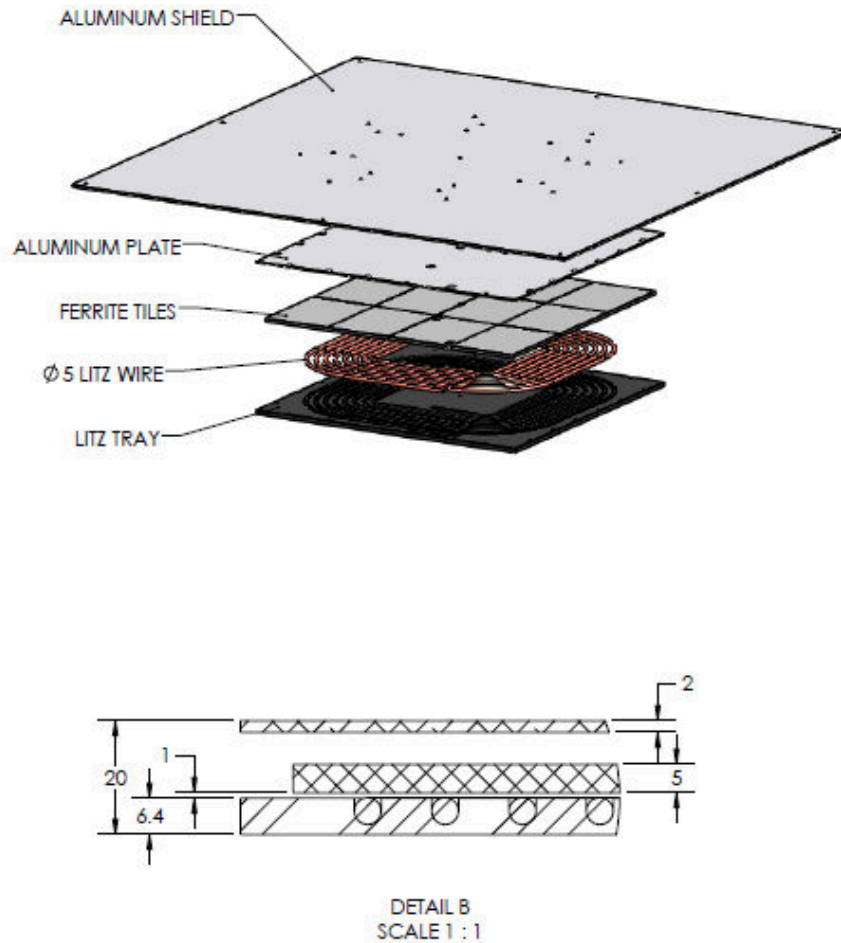

**Figure A32 - Exploded view of the Test Station VA WPT3/Z3**

Table A17 shows the mechanical dimensions of the VA WPT3/Z3 and nominal vehicle shield.

**Table A17 - Mechanical dimensions of the Test Station VA WPT3/Z3**

	<b>Coil + Ferrite Only</b>	<b>Housing</b>	<b>Vehicle Shield Size</b>
L x W x H [mm]	401.5 x 401.5 x 12.6	420x 420 x 20	800 x 800 x 1

## A.9.2 Electrical Specification

Figure A33 shows the electrical specification of the VA WPT3/Z3.

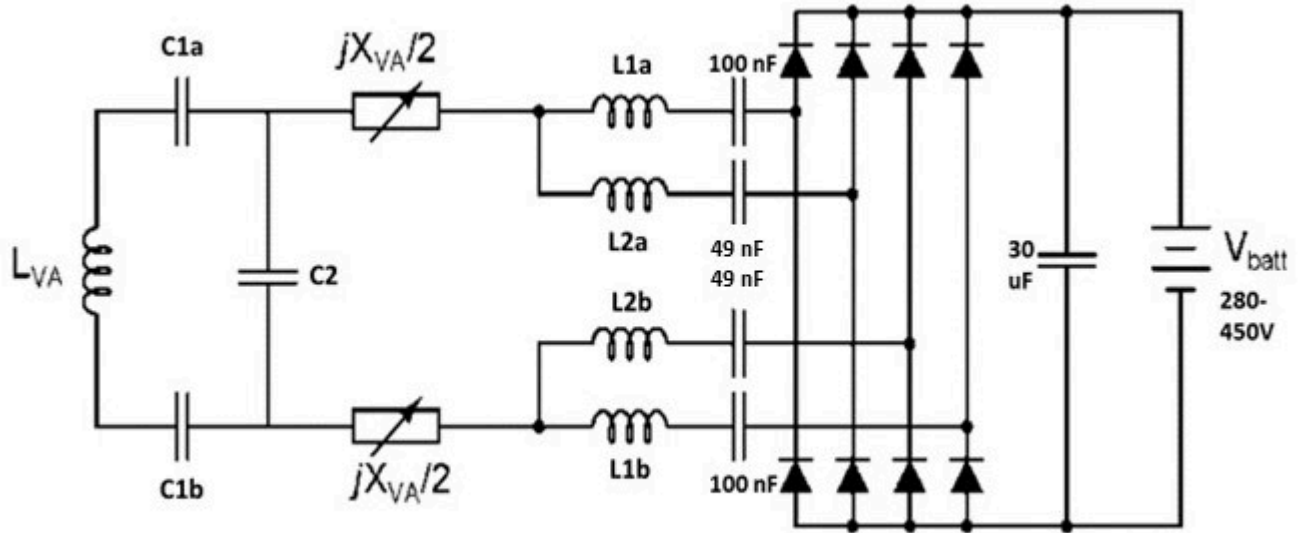

C1a, C1b [nF]	325
C2 [nF]	150
$jX_{VA}/2$ [ohms]	-15 to 0
L1a, L1b [ $\mu$ H]	54
L2a, L2b [ $\mu$ H]	54

**Figure A33 - Electrical specification of the Test Station VA WPT3/Z3**

Minimum and maximum values of secondary coil inductance  $L_{VA}$  are given in Table A18.

**Table A18 - Secondary coil inductance  $L_{VA}$**

$L_{Min}$ [ $\mu$ H]	39.3
$L_{Max}$ [ $\mu$ H]	40.0

## APPENDIX B - TEST STATION UNIVERSAL GA (WPT1, WPT2, WPT3) (NORMATIVE)

This appendix provides the mechanical and electrical design specifications of the Test Station Universal GA.

NOTE: Specifications designed for optimal operation with the Test Station VA WPT2/Z1 (Appendix A.4), the Test Station VA WPT2/Z2 (Appendix A.5), the Test Station VA WPT2/Z3 (Appendix A.6), the Test Station VA WPT3/Z1 (Appendix A.7), the Test Station VA WPT3/Z2 (Appendix A.8), and the Test Station VA WPT3/Z3 (Appendix A.9).

## B.1 MECHANICAL SPECIFICATION

Figures B1 and B2 show the mechanical dimensions of the Test Station Universal GA. Figure B3 shows an exploded view of the mechanical construction of the GA with the aluminum plate towards the ground. The ferrite layers in the GA are constructed of ferrite tiles of dimensions 100 x 150 x 5 mm and 100 x 100 x 5 mm. Typical properties of the ferrite material used in the GA are shown in Table B1.

**Table B1 - Typical Ferrite Properties**

Material	MnZn
Initial Permeability (25 °C)	>1000
Flux Density, $B_s$ (100 °C) ( $H = 1200$ A/m, 10 kHz)	>400 mT
Core Loss, $P_v$ (100 kHz, 200 mT, 100 °C)	<350 kW/m <sup>3</sup>

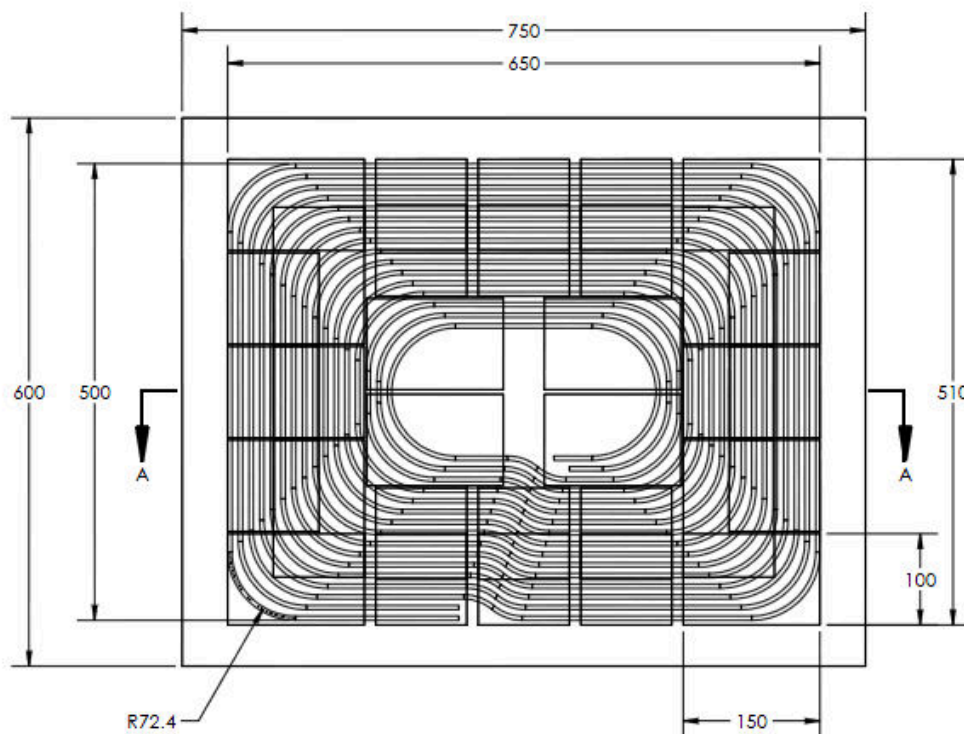

**Figure B1 - Mechanical dimensions of the Test Station Universal GA**

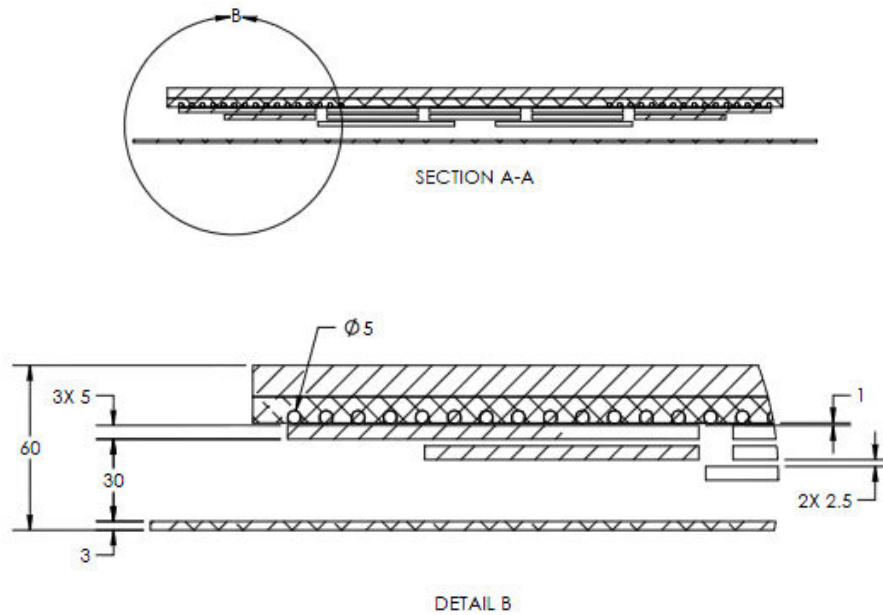

**Figure B2 - Detailed cross section view of the Test Station Universal GA**

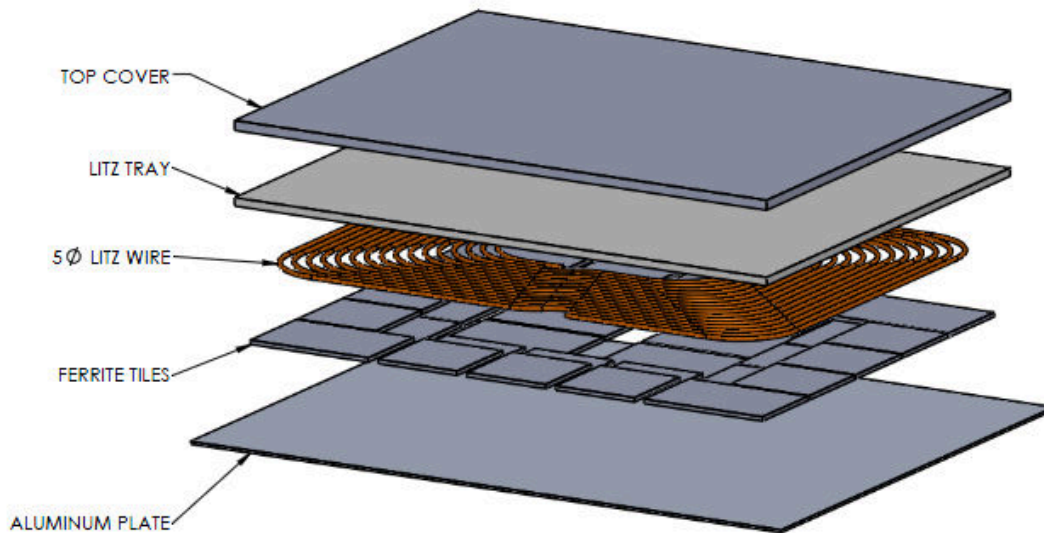

**Figure B3 - Exploded view of the Test Station Universal GA**

NOTE: Ferrite placed on a single plane rather than at three levels can also be used but will result in a slight change of inductance and coupling values.

## B.2 ELECTRICAL SPECIFICATION

Figure B4 and the values in Table B2 show the electrical specification of the Test Station Universal GA.